

FOLDING PTO MIXER



RECK



Homogeneous slurry

Homogeneous slurry is a regular composition of the mineral fertilizer. Only in this way a regular spreading from the first to the last load is possible. Best farmland and grassland yields due to the best possible fertilization.

Extra costs for fertilizer can be reduced. Efficiently mixed slurry can be used in conjunction with umbilical and injection systems. A regularly liquid is also important for a complete emptying of the slurry pit and a quick filling of the tanker.

folding · In easy

Folding mixer for draft links and tractor clevis

The mixer model Tiger can be used in small pit openings (from about \varnothing 60cm) **due to the cranked folding frame**. Attachment to the draft links **and the tractor clevis**. The insertion and height adjustment of the mixer can be operated through the tractors hydraulics from the seat. There are no hoist chains and manual spindles necessary. The height adjustable clevis bow allows a regular bending of the normal

cardan shaft and an adjustment to the different circumstances and tractor sizes. There is no restless up and down of the slurry mixer during stirring up because of the twisting in the tractor clevis. The folding PTO mixer Tiger is available from **3,60 m to 6,2 m** length (Interim lengths are available on request).



Attachment to the tractor clevis Tiger



Advantages of the RECK Folding PTO Mixer

- Homogenizes strongest surface crusts and settings due to the enormous mixing performance of the specially formed high efficiency propeller, available in pushing or pulling version
- Easy process of insertion from tractor's seat
- Usable even in the smallest slurry pit openings
- Up to 800 revolutions per minute are possible
- The folding frame, which is adjusted to each length of the mixer, makes the locking of the tube easier
- Comfortable safety lock in order to attach the mixing tube
- Long lasting, ball bearing free special slide mounting of the drive shaft in the aggressive slurry- insensitive to leftovers, straw and animal hair

section · hom
liquid time

Adjustment through manual spindle

The mixer model Gepard **can be used even in bigger slurry pit openings (from about \varnothing 80 cm)** due to the cranked folding frame. The attachment of the mixer is on the tractor's three point linkage (draft link and upper link). The insertion and the depth adjustment can be done

by the tractors hydraulics **and** the manual spindle. The Gepard mixer can be used as well in closed circuits or slalom systems. The folding PTO mixer Gepard is available from 4,60 m to 6,60 m length (interim lengths are available on request).



With manual spindle Gepard



Easier mixer insertion with the inserting auxiliary hydraulic

Technical innovation parts from details. Time is a valuable factor in the agricultural sector, which is why the company RECK has developed a **inserting auxiliary hydraulic**. To make the mixer inserting easier RECK can offer an

inserting auxiliary hydraulic for each of the folding PTO mixers. With the additional hydraulic cylinder you can move the mixer tube. That makes locking of the mixer tube easier (details see in the accessories).

ogenesis saving

Adjustment through hydraulic cylinder

The mixer model Jaguar can be used in small pit openings (from about \varnothing 60 cm) **due to the cranked folding frame**. The attachment of the mixer is on the tractor's three point linkage (draft link and upper link). Easy and smooth insertion of the slurry mixer with the additional

hydraulic cylinder, independent of the tractor's hydraulic which is often inexact. A regular and even bending of the two universal joints of the standard cardan shaft is possible through the hydraulic cylinder and the tractor's hydraulics. This allows operating with little wear on the standard cardan shaft. Available from **4,60 m to 7,6 m** length (Interim lengths are available on request).



With hydraulic cylinder Jaguar

RECK
Agrartechnik

Vast variety of mixer types

For the individual requirements of our customers we can offer a great number of different mixer combinations. Our big product range offers an ideal mixer combination for a high performance and effective operation. We advise you gladly!

Equipment	Mixer tube ø in mm	Mixer shaft ø in mm	Propeller in mm	Folding frame	Bearings	Length of mixers in m
Standard version	101	35	440 - 650	Standard version	Standard version	4.0 - 6.6
Strong version	140	35	440 - 650	reinforced	extra reinforced	4.2 - 7.6
Extra strong version	140	45	550 - 650	reinforced	extra reinforced	4.2 - 7.6

Hight efficiency propeller

- All three bladed high efficiency propellers are available in pushing or pulling version
- All high efficiency propellers are also available in another propeller version (optimized position of the propeller blades)
- For small openings (up to ø 25cm) a two bladed folding propeller is available

Special slide bearings

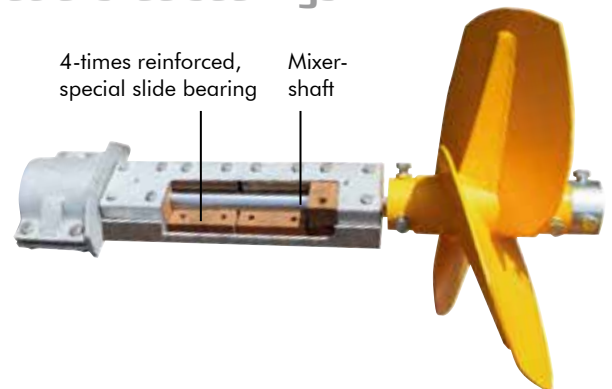

section
homogenise

Accessories

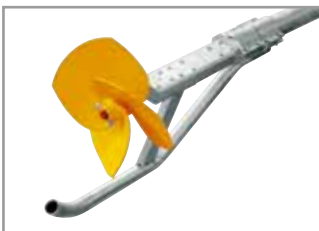

Propeller stay long



Propeller stay short



High efficiency shredder (propeller stay needed to install the counter blade)



Inserting auxiliary hydraulics



Reverse transmission (for pushing and pulling mixing)

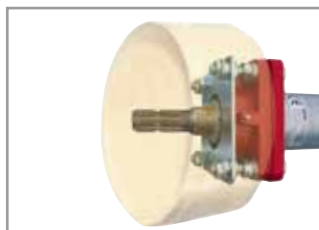

Reinforced bearing unit



Chassis for mixer



Cardan shaft

FOLDING PTO MIXER

Reck Agrartechnik

RECK-Technik GmbH & Co. KG
Reckstrasse 1-5
88422 Betzenweiler, Germany
Telephone: +49 (0) 7374 18-83
Telefax +49 (0) 7374 18-466
info@reck-agrar.com
www.reck-agrar.com

IDN 100.010.907 Stand 2017_05 EN
We reserve changes which serve the technical progress. Reprint, also extracts require a
written permission of the RECK Company. Certified in Quality Management ISO 9001.

